



HRE-1500-4 HEAT REACTIVATED DESICCANT AIR DRYER GENERAL ARRANGEMENT

TOLERANCES UNLESS
OTHERWISE SPECIFIED:

- FRACTIONS = ± 1/4 "
- ANGLES = ± 3°
- INCHES = ± 1/2 "
- FINISH = 250

THE SPECIFICATIONS AND DRAWINGS DISCLOSED HEREIN ARE THE SOLE PROPERTY OF ALTEC AIR, AND SHALL NOT BE COPIED OR USED AS THE BASIS FOR SALE OR MANUFACTURE WITHOUT EXPRESS WRITTEN PERMISSION.

REVISION LOG

REV.	ECO.	DESCRIPTION	DATE	APPROVED
B	1090	PRODUCTION UPDATES	2/8/2021	WS

DRAWING NO.

AT20-950

REV.
B

DRAWN: WS DATE: 8/29/2017
CHECKED: DATE:

SCALE: N/A SHEET: 1 OF 2

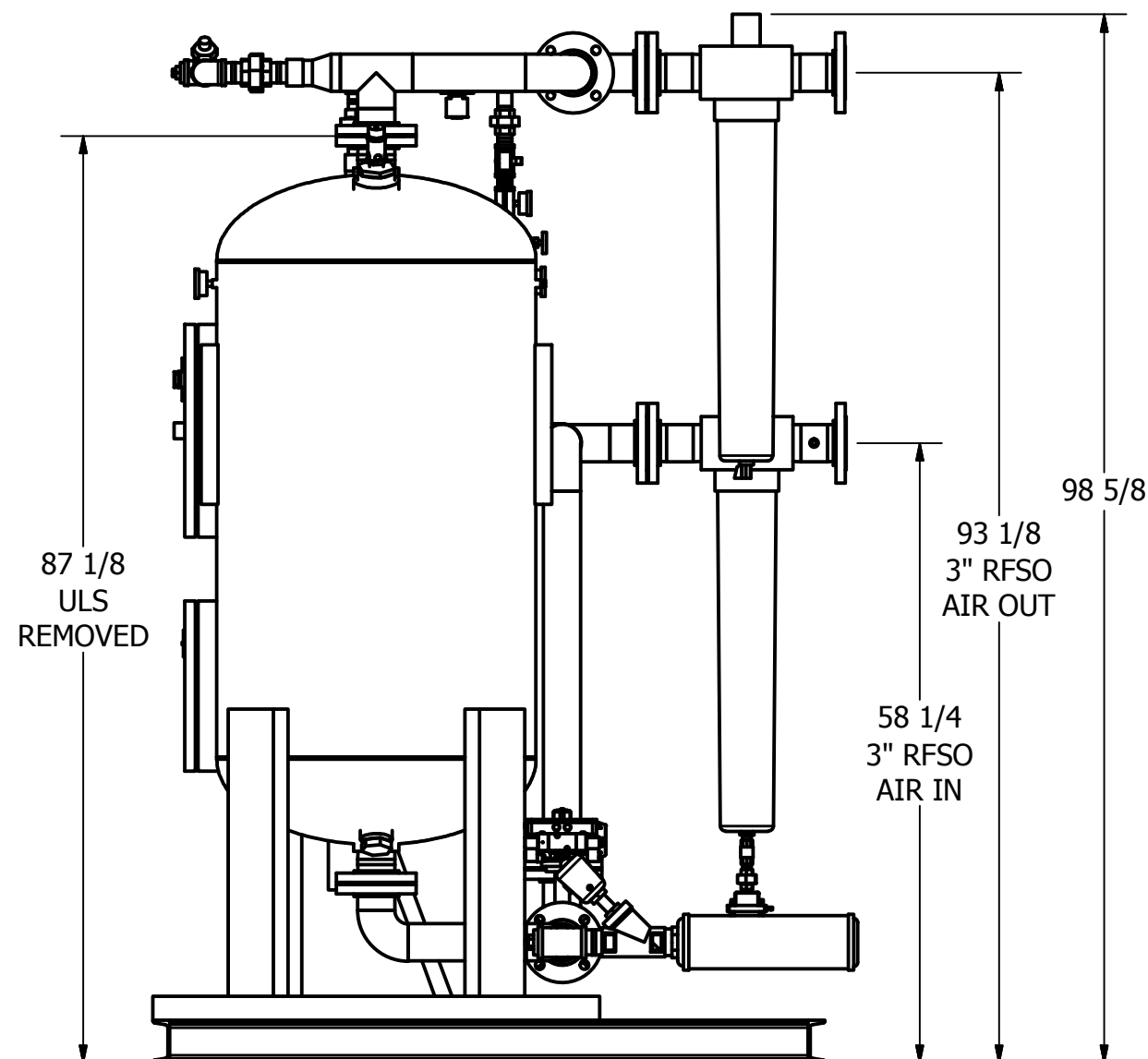
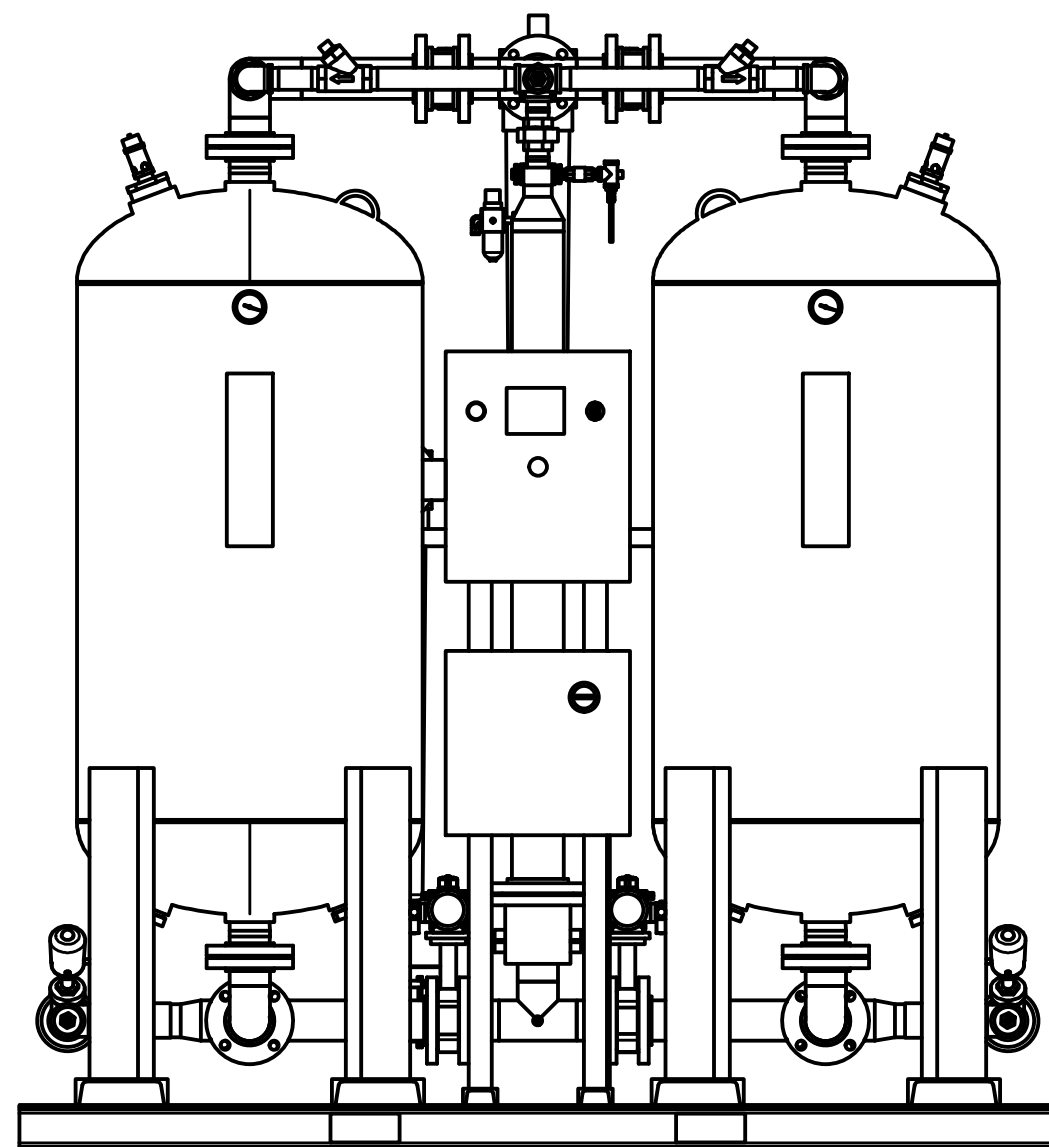
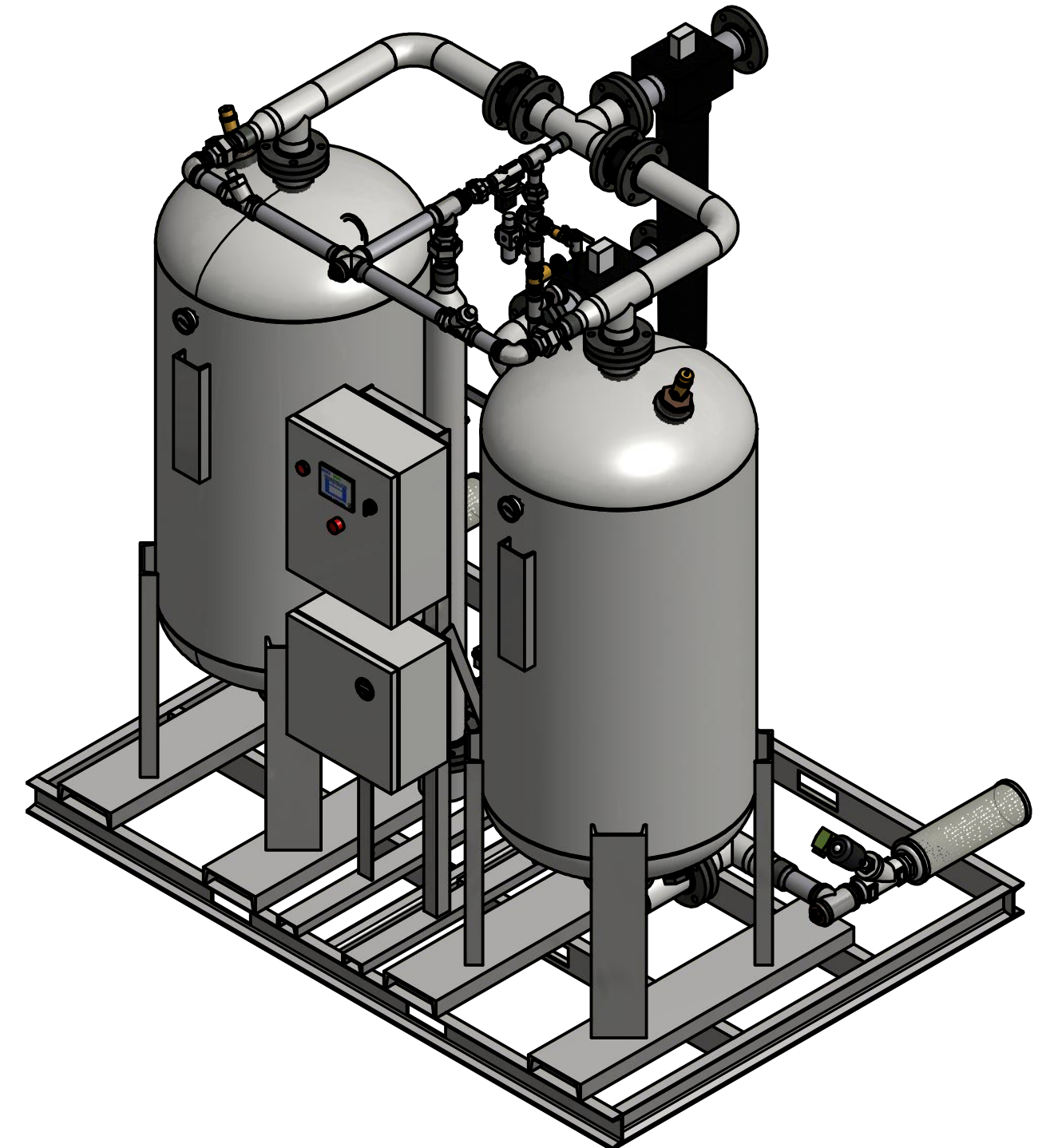
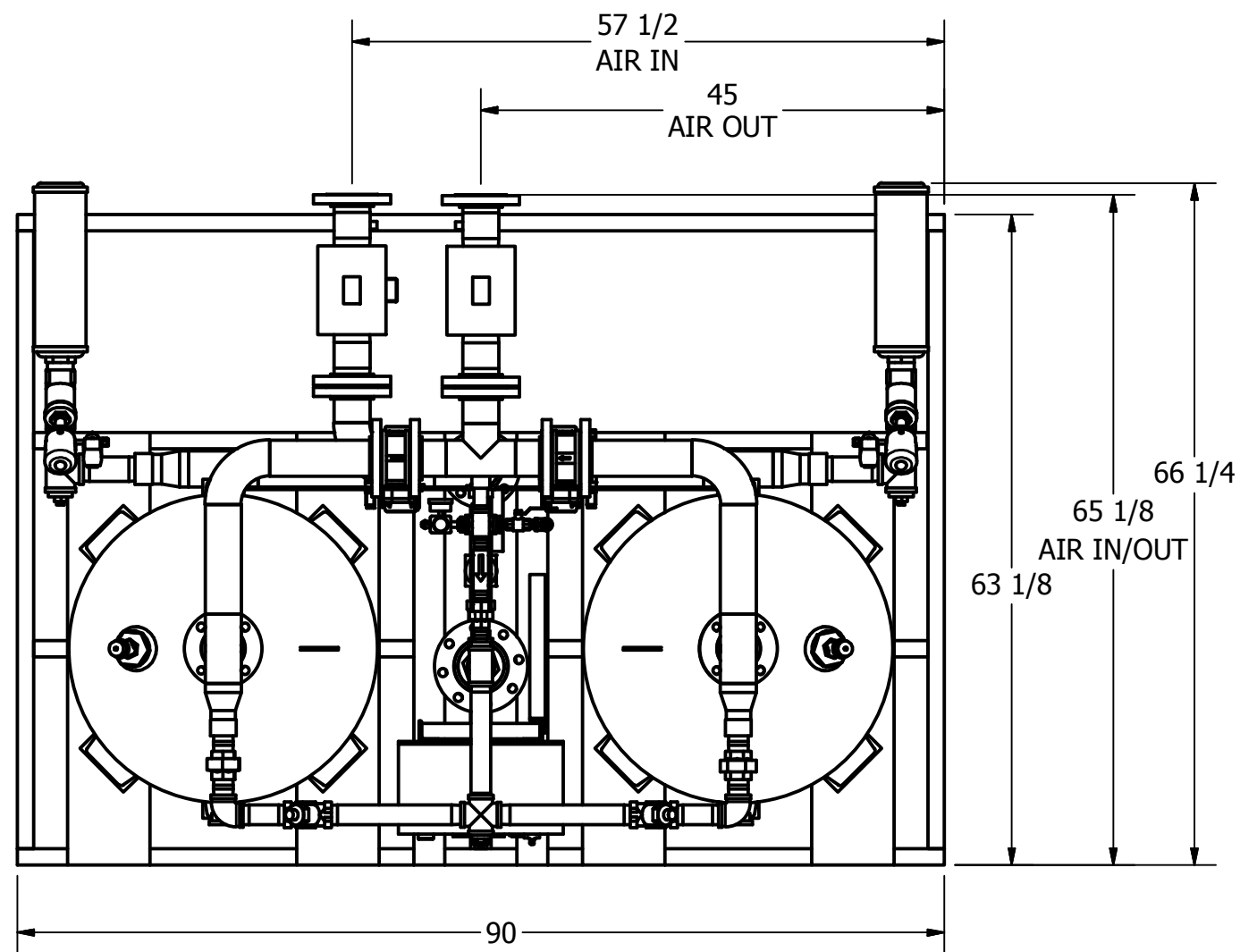

PRELIMINARY



HRE-1500-4 HEAT REACTIVATED DESICCANT AIR DRYER GENERAL ARRANGEMENT

TOLERANCES UNLESS
OTHERWISE SPECIFIED:

- FRACTIONS = ± 1/4 "
- ANGLES = ± 3°
- INCHES = ± 1/2 "
- FINISH = 250

THE SPECIFICATIONS AND DRAWINGS DISCLOSED HEREIN ARE THE SOLE PROPERTY OF ALTEC AIR, AND SHALL NOT BE COPIED OR USED AS THE BASIS FOR SALE OR MANUFACTURE WITHOUT EXPRESS WRITTEN PERMISSION.

REVISION LOG

REV.	ECO.	DESCRIPTION	DATE	APPROVED
B	1090	PRODUCTION UPDATES	2/8/2021	WS

DRAWING NO. **AT20-950** REV. **B**

DRAWN: WS DATE: 8/29/2017
 CHECKED: DATE: SCALE: N/A SHEET: 2 OF 2

PARTS LIST

ITEM	QTY	DESCRIPTION
1	2	CHECK VALVE, PURGE
2	1	SOLENOID VALVE, REPRESS
3	2	CHECK VALVE, OUTLET
4	1	PRESSURE REGULATOR, CONTROL
5	1	PRESSURE GAUGE, CONTROL
6	1	PARTICULATE AFTER-FILTER
7	1	GATE VALVE, PURGE
8	1	PRESSURE GAUGE, PURGE
9	1	COALESCER PRE-FILTER
10	1	DEW POINT MONITOR (OPTIONAL)
11	2	RELIEF VALVE, TANK
12	2	PRESSURE GAUGE, TANK
13	1	18 KW HEATER
14	1	ZERO LOSS DRAIN
15	2	BUTTERFLY VALVE, INLET
16	2	ANGLE BODY VALVE, EXHAUST
17	2	MUFFLER, EXHAUST
18	2,200 LBS	DESICCANT

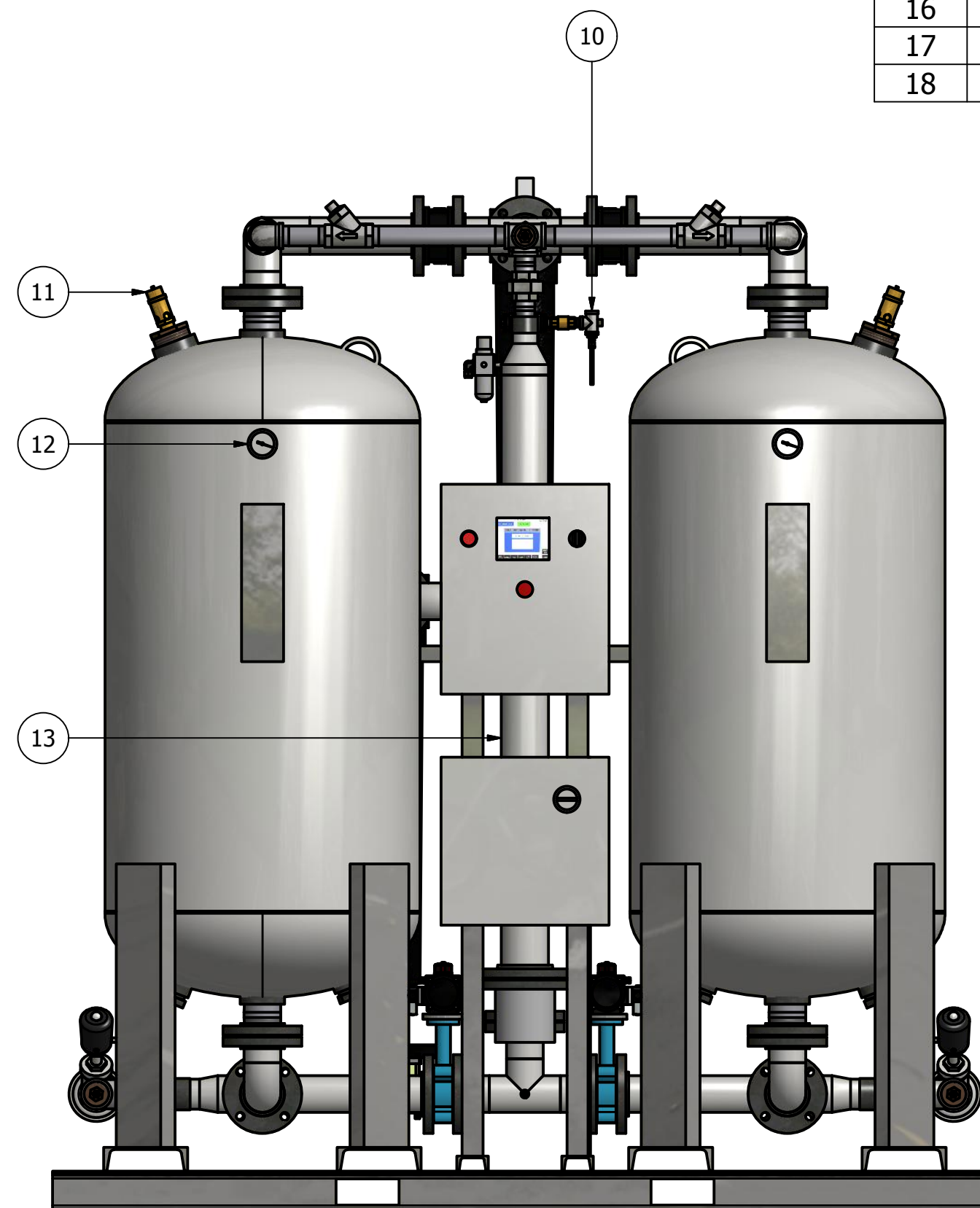
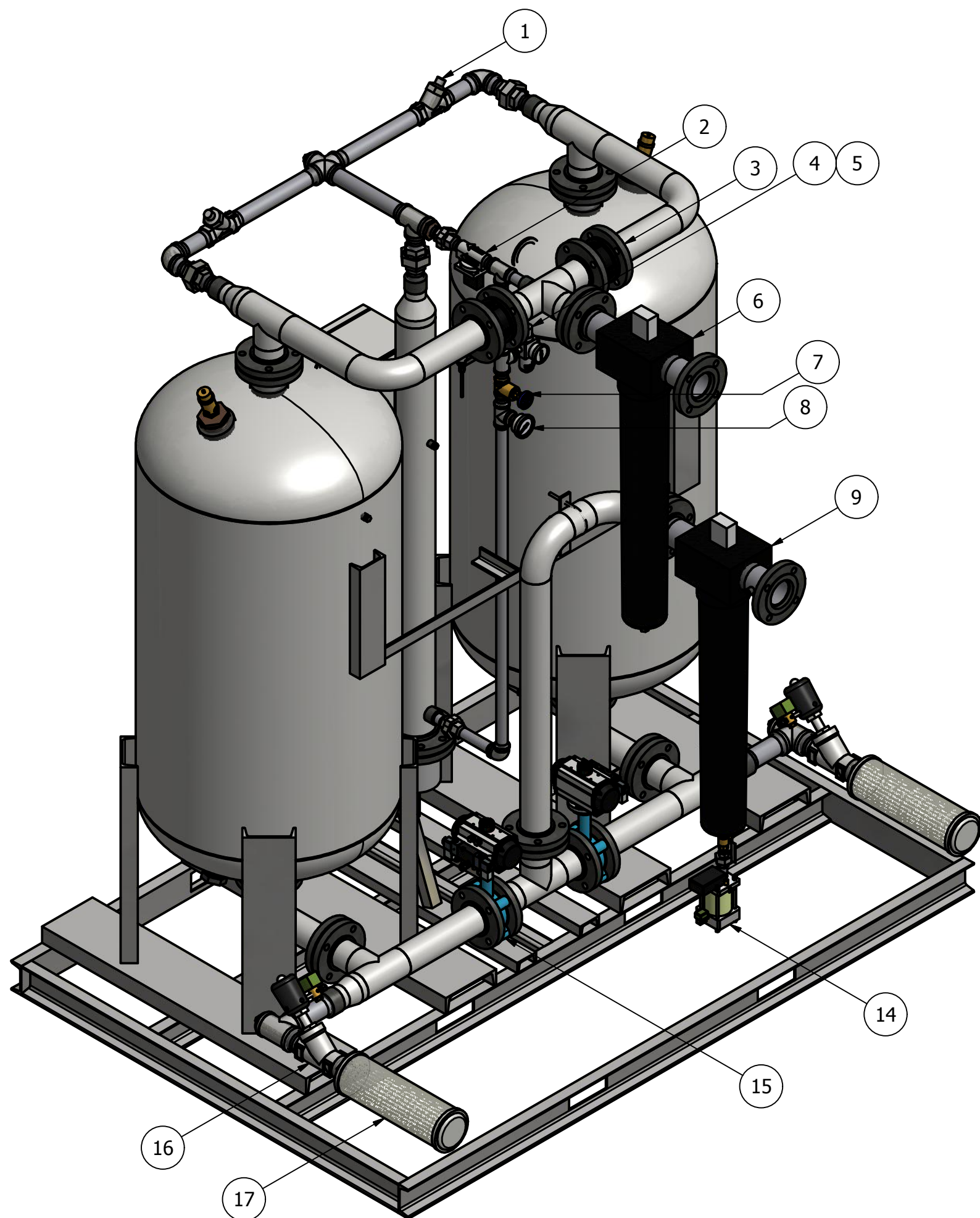

PRELIMINARY